

This carefully produced downloadable and printable net file represents an iconic Hassleblad camera as a low impact and functional product that is available to all.

The often problematic nature of desire and ownership are potentially both exorcised and reconciled by the act of 'making' this object yourself without actually possessing the 'original' of this exclusive of all cameras.

Images created by the community of users will be viewable at www.pinholehasselblad.tumblr.com. Please send any images of your camera or produced by your camera to pinhole@kellyangood.co.uk to be uploaded to the blog.

www.kellyangood.co.uk
pinhole@kellyangood.co.uk
©

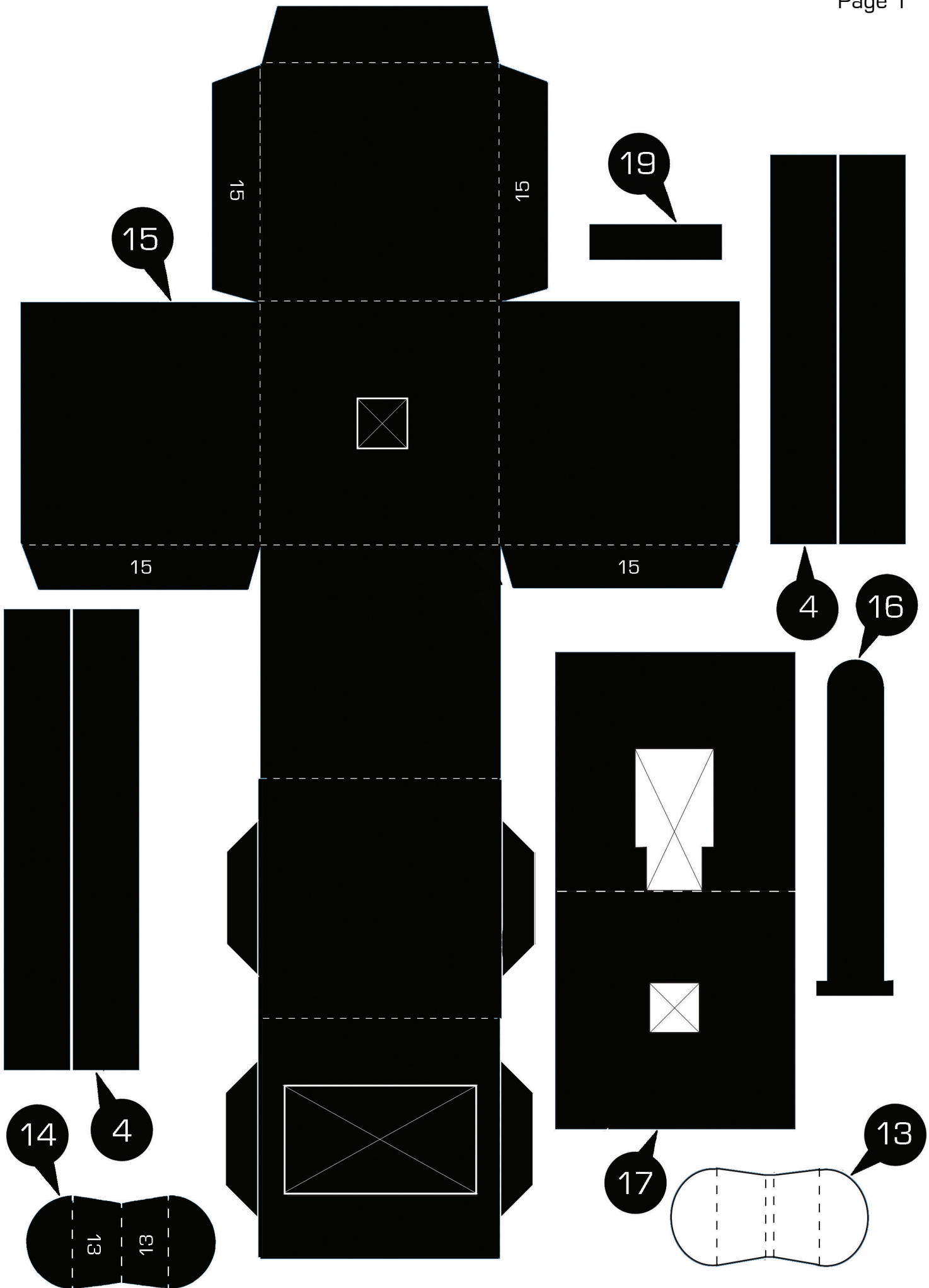
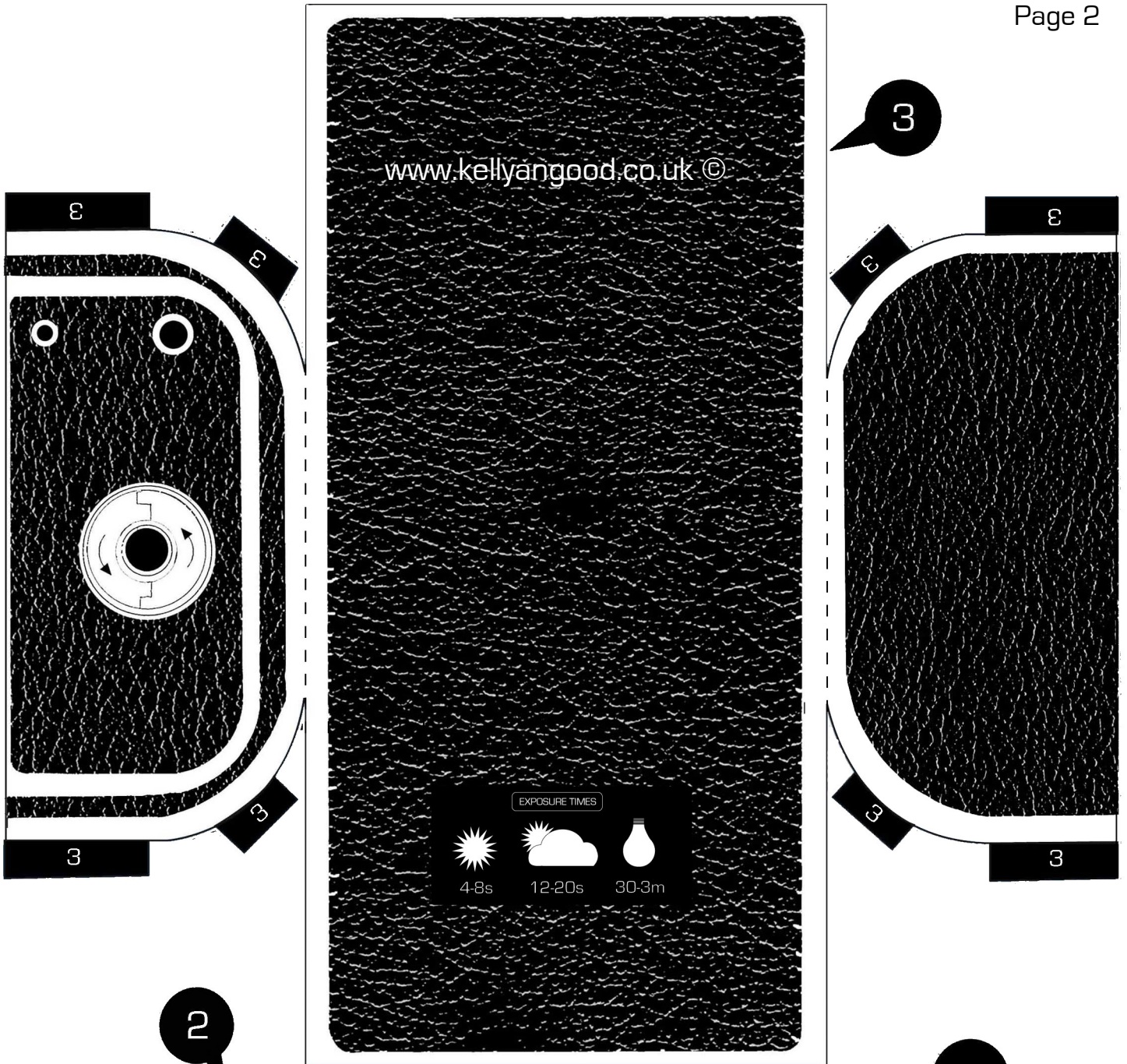



2

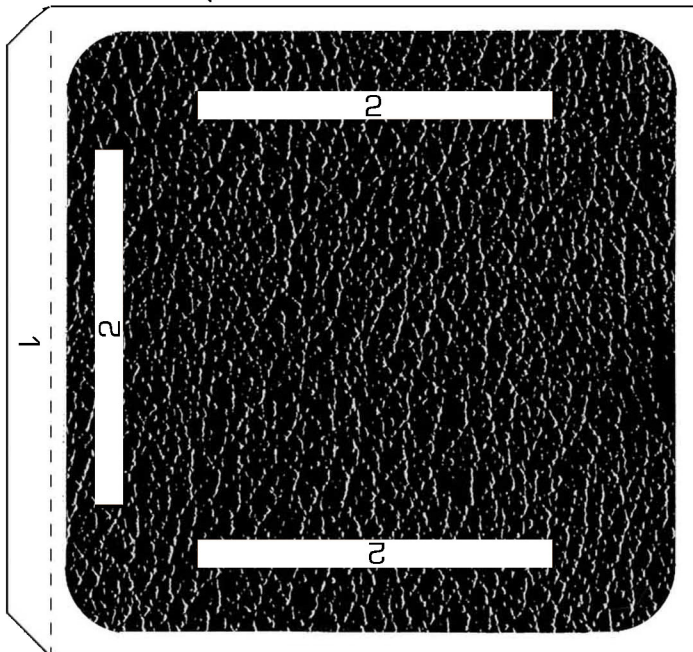

6

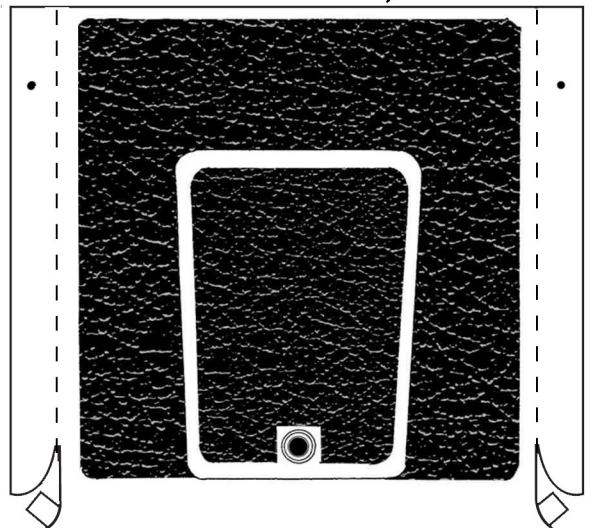

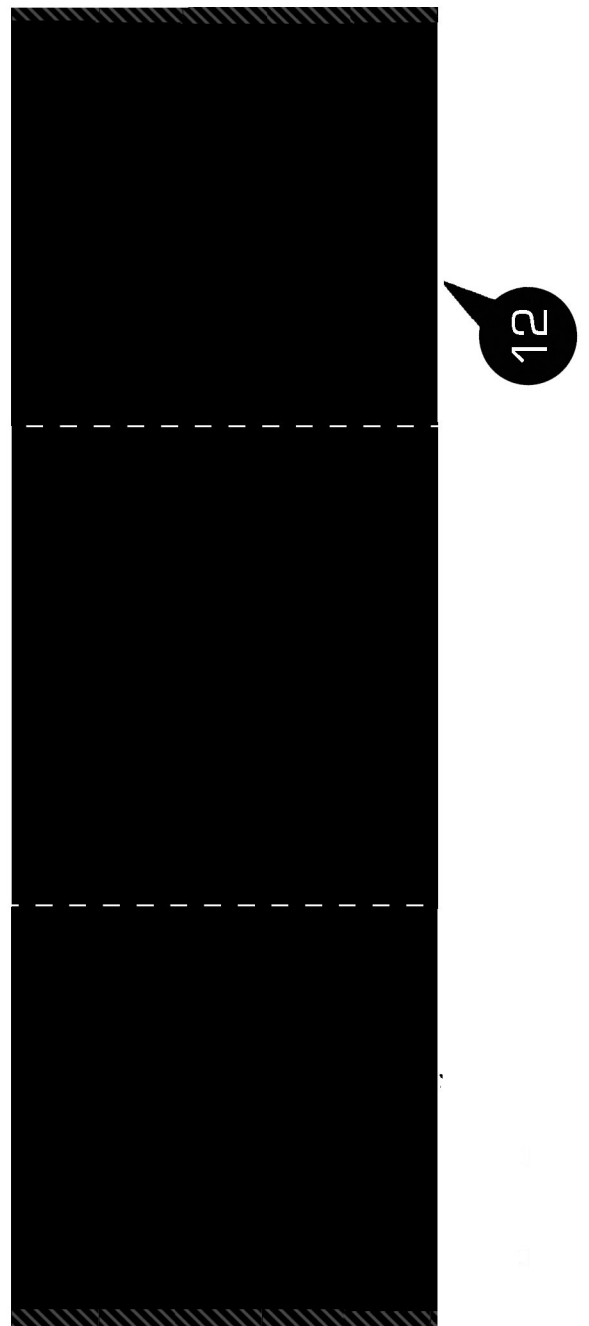
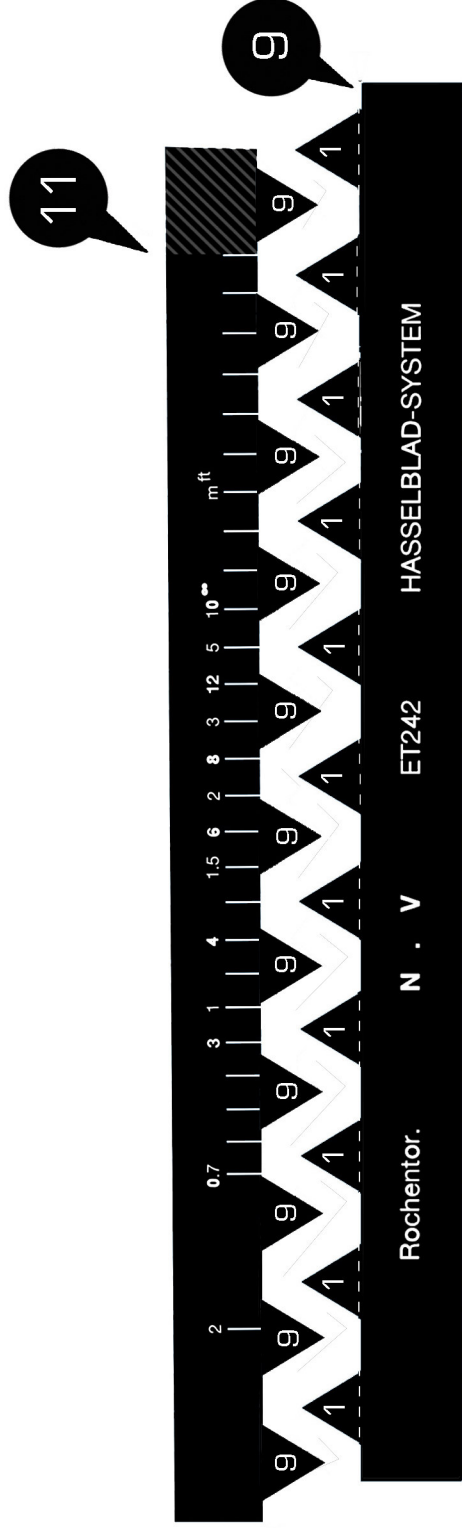
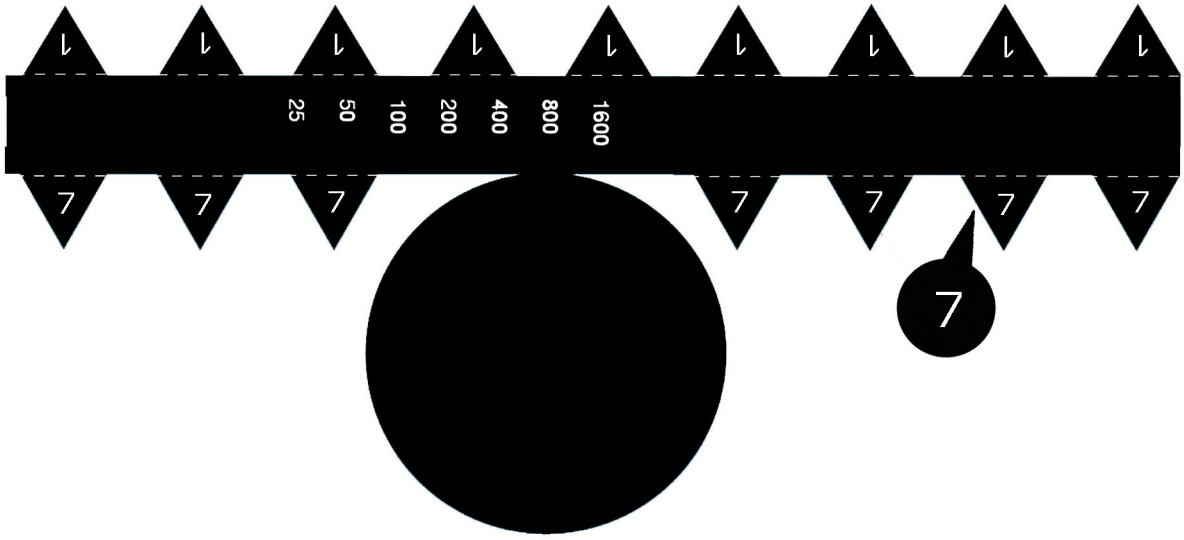

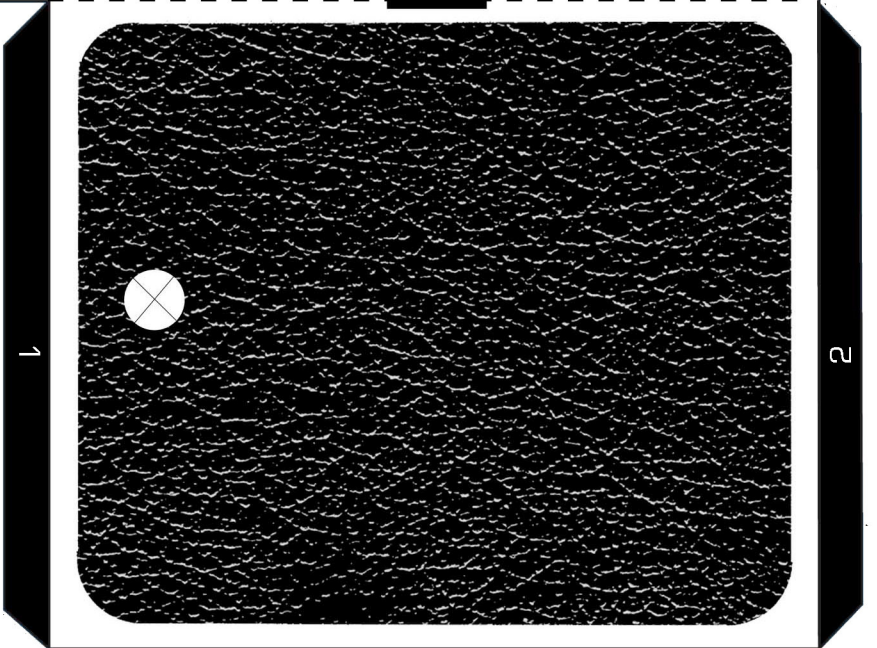
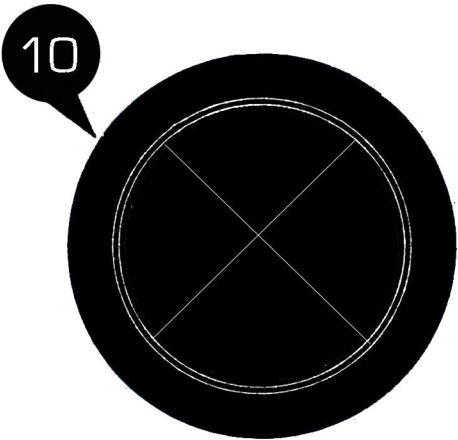
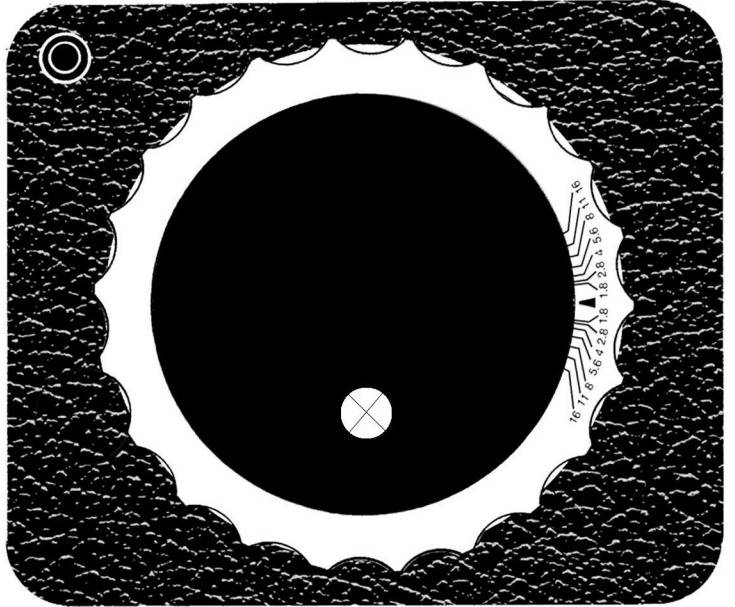
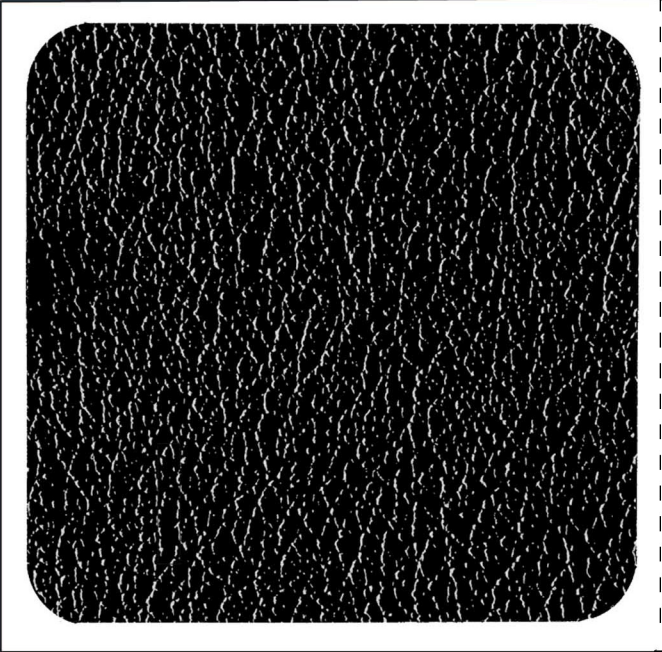
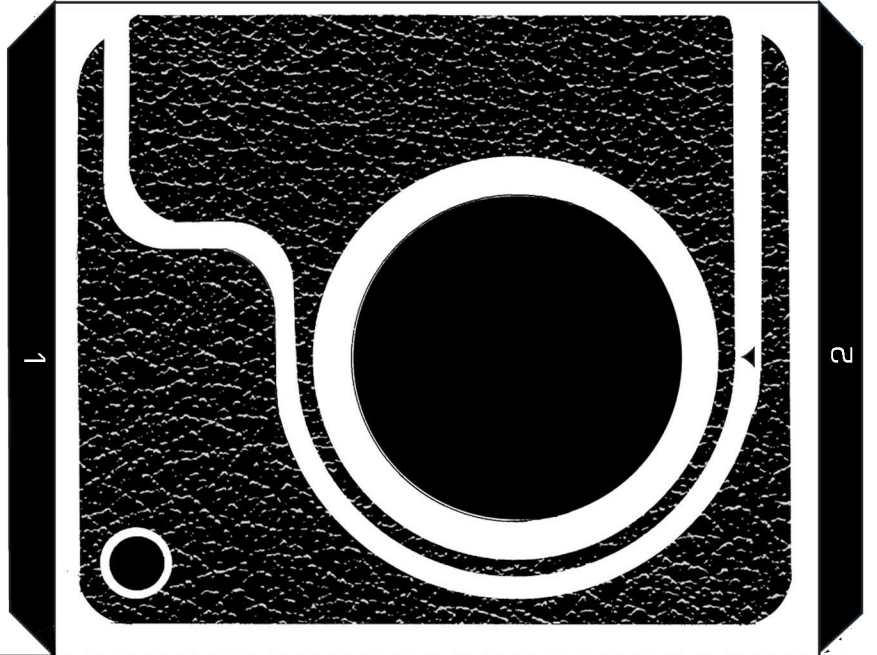
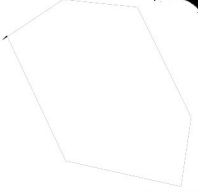
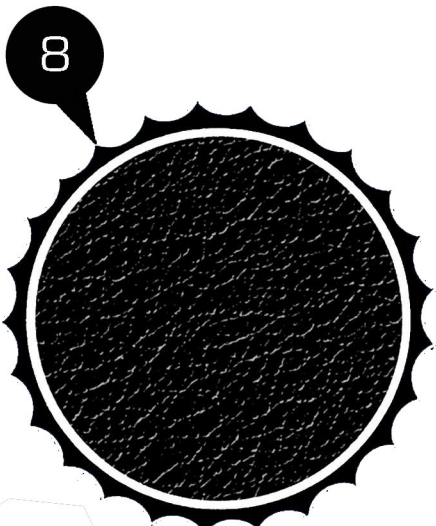

MAIN BODY

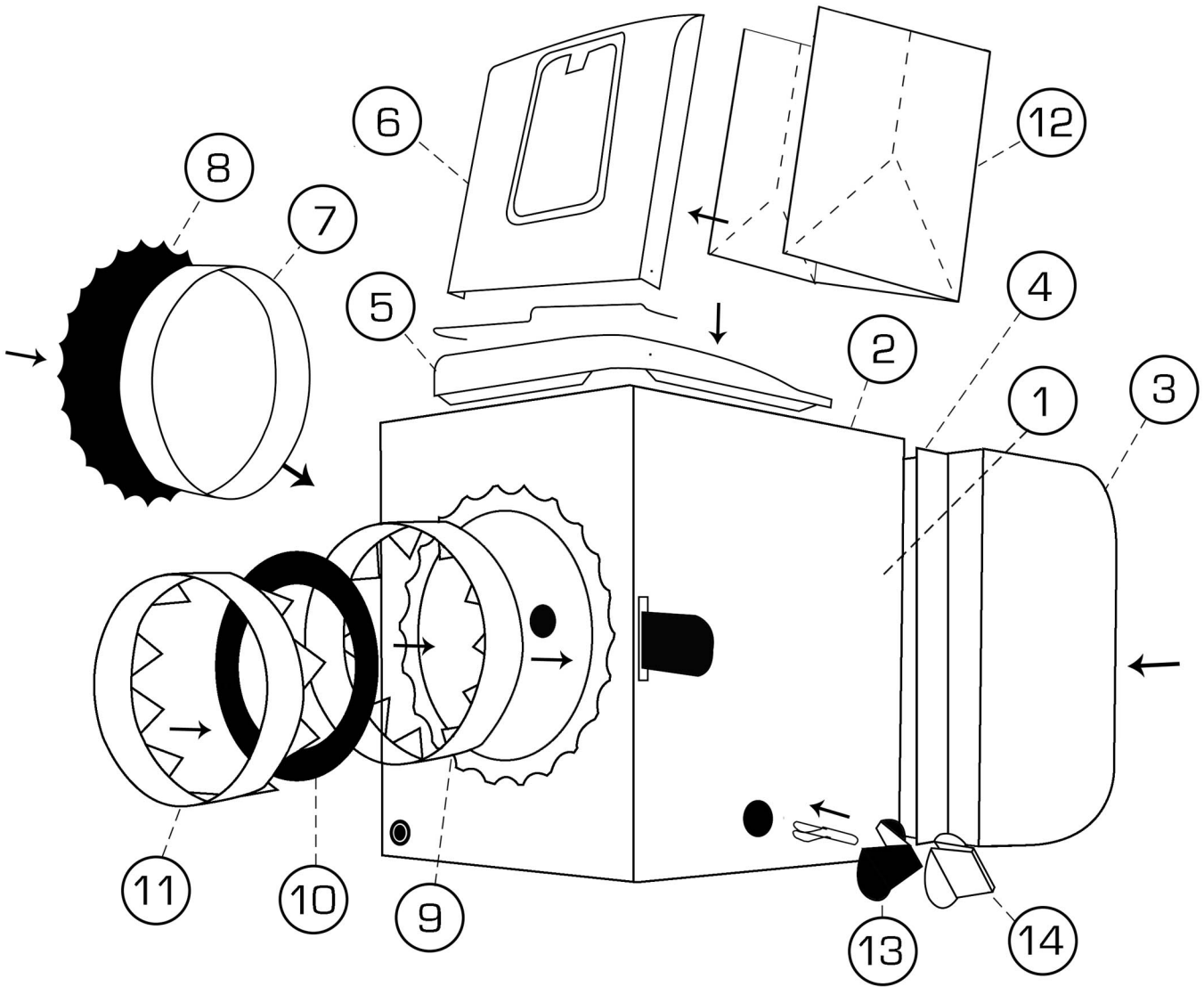

FILM MECHANISM

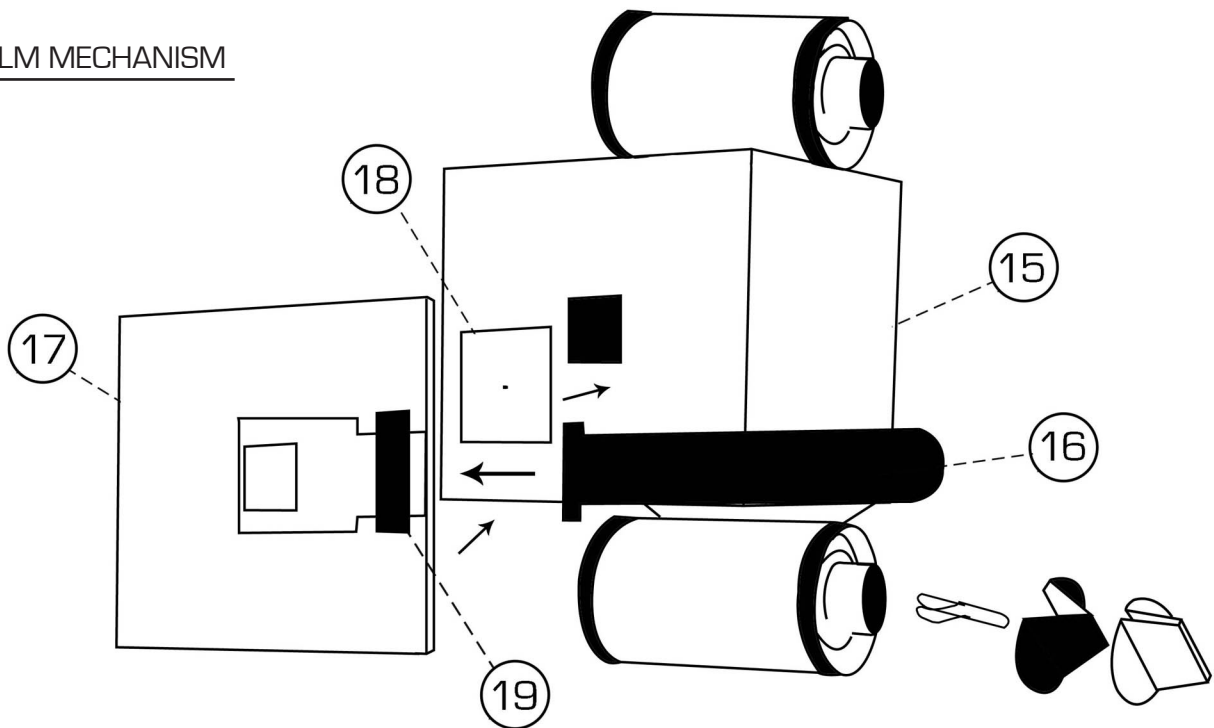

INSTRUCTIONS

Please refer to the diagrams and instructional video if you need further assistance in making your pinhole Hasselblad

Notes

- Print this PDF on regular A4 office paper at 1:1 (called 100% on some printers). DO NOT select 'fit to page'. To ensure that you have printed the document correctly measure the rulers on each page against a real ruler. If the document is printed smaller than intended your film will not fit in the mechanism!

- Your pinhole Hasselblad will accept any 35 mm film. Use a 200ISO film for best results as this is what the suggested exposure times are based on.

- Numbers on the tabs indicate which cut-out the tab should be glued to.

Apart from the print out you will need-

A scalpel or craft knife

A ruler (preferably metal)

2 regular paper clips

A cereal box

Either a 2cm x 2cm square of aluminum foil or a square of aluminum from a drinks can and a sewing needle.

3 x A4 sheets of 150gsm black paper

Spray adhesive or a glue stick

Glue (UHU or PVA is recommended)

2 x 35mm 200ISO films

A roll of black electrical tape

A bottle opener

STAGE 1: Initial steps

🕒 00:00:00 > 00:00:38

- 1) Print out the PDF as instructed.
- 2) Cut away a roughly A4 sized section from your cereal box.
- 3) Using your glue stick or spray adhesive stick page one of the PDF to the printed side of your piece cereal box and stick pages 2-4 to your black paper.
- 4) Make all the cut outs from pages 1-4 taking special care to remove the inner cut outs from pieces 1, 10, 15 & 17.
- 5) Lightly score along the dashed lines on your cutouts to make folding easier.

STAGE 2: Making the main body

🕒 00:00:38 > 00:04:25

- 1) Fold cut out 1 into a three sided box and glue the tabs to the inside of the box to secure.

2) Now attach cut out 2 to the top of the box to complete the main body.

3) Take the rectangular cut outs (4). Glue the longer lengths to sides of the box, sticking them so that half of the width is inside the box and half sticking out. Do the same with the shorter lengths along the top and bottom of the box.

4) Now take cut out 3. Create a slight curve in the rectangular section by gently pulling the paper through your fingers. Do this to the upper and lower parts of the rectangle.

5) Now glue the tabs to the inside of the rectangular section. You may wish to hold some of the tabs together with paper clips whilst the glue dries.

6) When both the front box section and rear curved section are dry take your black electrical tape and tape along the inside of the joints. This is to prevent light-leaks.

STAGE 3: Making the roof

🕒 00:04:25 > 00:07:17

- 1) For this section you will need cut outs 5,6,12, a paper clip and a sewing needle.
- 2) Construct cut out 6 by folding along the dashed lines, making a slight curve at the front where the tabs are and glueing the tabs to the inside of the side sections. You may wish to hold the tabs to the main roof body with paper clips whilst they are drying.
- 3) When dry take your sewing needle and punch a hole through the small marker on both cut-outs 5 and 6.
- 4) Now glue cut out 5 to the top of the main body where indicated.
- 5) Open out your paper clip and shape as illustrated in the diagram.
- 6) When 5 and 6 are dry feed the paperclip through the holes you have made in 5 and 6 to attach them together. This can be a little tricky. When the mechanism is in place you should be able to move the roof of the Hasselblad up and down.
- 7) Now fold cutout 12 into a three sided box and glue the striped area to the inside of the inside of the roof section (6).
- 8) When dry hold the back of 12 with your fingers and push down 6 with gentle force. This will allow you to move the roof up and down and create the folds as illustrated in the diagram.

STAGE 4: Making the lens & side sections

🕒 00:07:17 > 00:10:40

- 1) For this section you will need cut outs 7, 8, 9, 10 & 11.
- 2) Take cut out 7 and fold down the triangular tabs on both sides.
- 3) Glue the triangular tabs marked 7 to the inside of the black circle and glue the two ends together where they meet.

- 4) Now glue the triangular tabs marked 1 to the circle on the side of the main body.
- 5) Now take cut out 8 and glue it to the circular surface of cut out 7. (See diagram)
- 6) Take section 9 and fold down the triangular tabs and glue to the front of the main body as previously done on cut out 7 taking care not to cover the cut out circle on the main body.
- 7) Glue cut out 10 to the inside of section 9.
- 8) Take cut out 11 and do not fold the tabs down but instead glue the tabs to the inside of section 9.

STAGE 5: Making the film mechanism

🕒 00:10:40 > 00:16:56

- 1) For this section you will need cut outs 15, 16, 17, 18, & 19. You will also need a 2cm x 2cm square of tin foil or aluminum, a sewing needle, black electrical tape, two 35mm films and a bottle opener.
- 2) Take cut out 15 and glue the tabs marked '15' to the inside of the box.
- 3) Now take section 17 and fold along the score line and glue together so that the black side is facing outwards.
- 4) When dry, place cut out 16 into cutout 17 and glue section 19 across the thinner section of the inner cut out from section 17 to prevent the slider from falling out. (See diagram).
- 5) Now take your square of tin foil or aluminum and place a pinhole directly in the centre then glue around the outer edges and glue to section 15 so that the pinhole is roughly in the middle of the central square cut out.
- 6) Glue the constructed sections 16, 17 & 19 to the front of section 15 as shown in the diagram.
- 7) Whilst that section is drying gently easy off the bottom of a 35mm film using a bottle opener. Take care not to damage it too much as the removed section has to be used again.
- 8) When you have removed the bottom, take out the film from the canister and discard.
- 9) Now remove the spool from the canister and turn it upside down.
- 10) Now pull a few centimeters of film from the second 35mm film canister and feed it into the empty spool. Depending on the film you are using you may need to cut some of the film away to create a tab to feed into the empty spool. You may also need to use a little electrical tape to make sure that the film is attached to the empty spool securely.
- 11) Slide the spool back into it's canister and push the section you removed with the bottle opener back onto the canister to secure.
- 12) You are now ready to attach the film to the constructed mechanism.
- 13) Place the exposed film onto the back of section 15 and fold the section with the rectangular cut out on top of the film.
- 14) When in place push the tabs into the film feed of the canisters. This helps to prevent light leaks.

- 15) When you have done this fold the last remaining tab over the back of the box and secure with black electrical tape to complete the section.
- 16) If you feel that there is anywhere in the mechanism where light could leak in (apart from the pin hole) cover with black electrical tape.
- 17) When the mechanism is fully dried, place glue to the front of the mechanism taking care to avoid the slider.
- 18) Then feed the mechanism into the main body of the camera, feeding the slider through the small rectangular cut out on the right of the main body.
- 19) When in place open the slider to ensure that the pinhole can be seen through the cutout in the front of the main body and that the side of the bottom film is accessible through cut out at the side of the main body.
- 20) When fully in place, close the slider and allow to dry fully.

STAGE 6: Making the film advance mechanism

🕒 00:16:56 > 00:18:30

- 1) For this section you will need a paper clip and cut outs 13 & 14.
- 2) Bend the paper clip as shown in the diagram.
- 3) Glue cut out 14 to the folded cut out 13.
- 4) Glue the shaped paper clip into the constructed sections 13 & 14. You may wish to use a paperclip to hold these in place whilst it dries.
- 5) When dry, place the constructed winder into the bottom film canister. This mechanism winds the film on, in the first instance make about 8 full winds before you take your first photo and from then on wind the film 1.5 full turns between each exposure.

Your pinhole Hasselblad is now ready to use. When the film is finished, remove the tape holding the mechanism together, remove the film and pull the film away from the top spool and feed it into the bottom spool. You can now take the film to be developed. As the exposures on the negatives are not spaced standardly you may find it easier to get the film 'develop only' without prints and scan them in to your computer using a negative scanner.

Please also remember send any images of or from your pinhole camera to pinhole@kellyangood.co.uk to be published on the the blog www.pinholehasselblad.tumblr.com
